

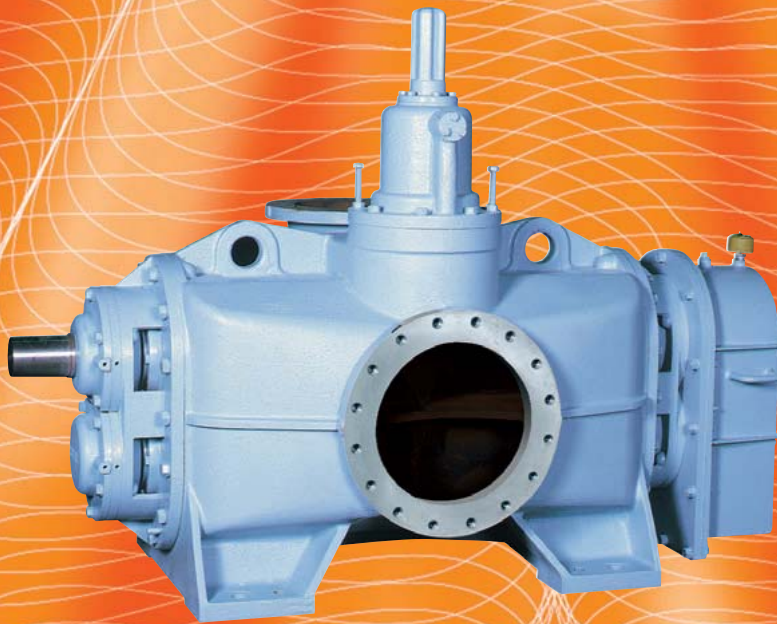

TWO-ROTOR SCREW PUMP

CSL
CSE

TWO-ROTOR SCREW



大晃機械工業株式会社
TAIKO KIKAI INDUSTRIES CO., LTD.

概要

大晃機械は、世界にさきがけて一点連続接触歯車ポンプの時代をつくり、歯車ポンプに新しい分野を拓いてまいりました。

創業来のポンプ技術を軸に、国内でもいち早く二軸ねじポンプに進出するとともに、二軸ねじポンプの汎用化に備えて、荷役ポンプシリーズを加えて、荷役ポンプシステムの多様化に应运てまいりました。

貨物油専用ポンプとして開発した“CSL、CSE”シリーズはオイルタンカやプロダクトキャリアの荷役ポンプとしての安全性を重視しながら小形・高性能を製品化しました。

■主用途

石油製品

：ガソリン・ナフサ・灯油・軽油・
ディーゼル油・重油等

食 品：

：アルコール（ワイン・ビール）等

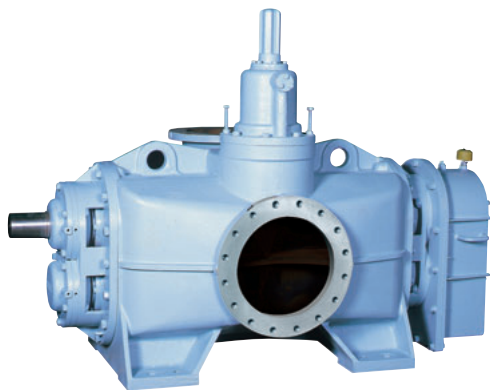

Outline

Taiko has opened a new field in the gear pumps by beginning, faster than any other country in the world, the age of a one-point-continuous-contact gear pump.

Not only did Taiko start manufacturing the Two-Rotor Screw Pumps promptly in Japan, but also it included a series of the cargo pumps in order to make provisions for further application of the two-rotor screw pump. Thus Taiko has coped with a wide variety of uses of the cargo pump.

The “CSL. CSE” series, pumps exclusively used for cargo-oil, have been recently developed by Taiko aiming at the safe operation of pumps as cargo pumps for oil tanker or product carrier ships. (Application for industrial ownership is pending) They are compact types with high performance.

■Principal application

Petroleum products

：gasoline, naphtha, Kerosene oil, light oil, diesel oil, heavy oil, etc.

Food

：alcohol(wine,beer)etc.

特 長

外装軸受式の二軸ねじポンプは、二本のねじ軸がポンプケーシングの中で滑らかに噛合って回転する容積型ポンプで、主動軸を駆動するとポンプケーシングの外側のタイミングギヤーにより従動軸も回転する。ケーシング内面とねじ外周の間、ねじの間それぞれ僅かの際間を保つ事ができるので摩擦・かじれ等を防ぎ、非潤滑性液・高粘度液・危険な液体等を取扱うのに最適のポンプです。

Feature

Two sets of screws, one left-handed and one right-handed, are housed in the pump casing. The liquid entering from the intake branches into two directions and is transferred to the center outlet from both sides of the casing. Therefore, complete shaft balance is maintained, and there is no thrust load applied to the bearing. Since clearance was maintained between casing and rotor, and between two rotors, no wear or leakage occurs. Thus, this pump is suitable for the handling of dangerous liquids, liquid with no-lubrication, and high-viscous liquid.

- | | |
|--|---|
| <ol style="list-style-type: none"> 1. 摩耗が僅少。 2. 非潤滑性液が扱える。 3. 高い自吸性能 (−8.5mAq) 4. 気液混合液が扱える。
(空気、ガス、泡等80%の気体を含む液体でも、充分空気を排出し、空気押しをする) 5. 高速回転ができ、振動や騒音が少ない。 6. 静かな連続吐出流が得られる。 7. 効率が良い。 | <ol style="list-style-type: none"> 1. Low abrasion. 2. Non-lubricating oil can be handled. 3. High suction performance(−8.5mAq). 4. Gas/liquid mixtures can be handled.
Liquid containing up to 80% of gas (such as air bubbles)can be de-gased. 5. High speed rotation is possible without oscillation or noise. 6. Quiet, continuous outlet flow is maintained. 7. High efficiency |
|--|---|

仕 様

Specification

Total Pressure 1.03MPa at 1mm²/s

吐出量 Capacity (m ³ /h)		50	100	150	200	300	400	500	750	1000	1200	1500
口 径 Bore (mm)		100×80	125×100	150×125	150×150	200×200	250×200	300×250	350×300	400×350	400×350	450×400
回転速度 Number of revolution (min ⁻¹)		1800	1500	1500	1500	1500	1500	1200	1200	1000	900	900
形 式 Type	Oil seal	50	100	150	200	300	400	500	750	1000	1200	1500
	Mechanical seal	50M	100M	150M	200M	300M	400M	500M	750M	1000M	1200M	1500M

構造及び材質

Structur & Material

CSL

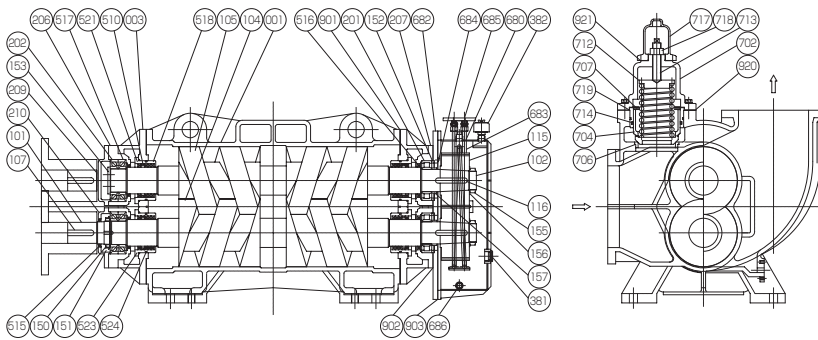

軸封詳細

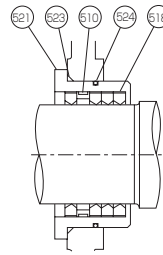

オイルシール式
Oil seal type

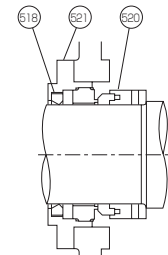

メカニカルシール式
Mechanical seal type

CSL形 部品表					CSL Type parts list			
No.	部品名称	材質 (JIS)	数量	備考	Parts name	Materials	Use	Remarks
001	ケーシング	FC200	1		Casing	Cast iron	1	
003	サイドケース	FC200	2		Side case	Cast iron	2	
101	主動軸	SUS403 (H)	1		Power shaft	Stainless steel	1	
102	従動軸	SUS403 (H)	1		Idler shaft	Stainless steel	1	
104	主螺旋	CAC302	2		Screw rotor (1)	Hi-streng. brass cast	2	
105	従螺旋	CAC302	2		Screw rotor (2)	Hi-streng. brass cast	2	
107	キー	S45C	1		Key	Carbon steel	1	
115	タイミング ギヤ	SCM420	2		Timing gear	Cr-Mo steel	2	
116	キー	S45C	2		Key	Carbon steel	2	
150	ベアリング ナット	SS400	1		Bearing nut	Mild steel	1	
151	ベアリング ワッシャ	SS400	1		Bearing washer	Mild steel	1	
152	カラー (A)	SS400	2		Collor (A)	Mild steel	2	
153	エンドプレート	SS400	1		End plate	Mild steel	1	
155	ギヤ ナット	SS400	2		Gear nut	Mild steel	2	
156	ギヤ ワッシャ	SS400	2		Gear washer	Mild steel	2	
157	スペーサ (B)	SS400	2		Spacer (B)	Mild steel	2	
201	円筒コロ軸受	SUJ2	2		Roller bearing	Bearing steel	2	
202	玉軸受	SUJ2	2 組		Ball bearing	Bearing steel	2 Sets	
206	軸受ホルダ (B)	FC200	2		Bearing holder (B)	Cast iron	2	
207	軸受ホルダ (A)	FC200	2		Bearing holder (A)	Cast iron	2	
209	軸受カバー (B)	FC200	1		Bearing cover (B)	Cast iron	1	
210	軸受カバー (A)	FC200	1		Bearing cover (A)	Cast iron	1	
381	レベルゲージ	ガラス	1		Level gauge	Glass	1	
382	エアブリーザ	ALC3	1		Air breather	Aluminiumcasting	1	
510	シールリング	SS400	4	オイルシール式	Seal ring	Mild steel	4	Oil seal type
515	オイルシール	NBR	1		Oil seal	NBR rubber	1	
516	オイルシール	NBR	2		Oil seal	NBR rubber	2	
517	オイルシール	NBR	2		Oil seal	NBR rubber	2	
518	オイルシール	FPM	16	オイルシール式	Oil seal	FPM rubber	16	Oil seal type
521	シールケース	FC200	4	オイルシール式	Seal case	Cast iron	4	Oil seal type
523	O-リング	FPM	4	オイルシール式	O-ring	FPM rubber	4	Oil seal type
524	O-リング	FPM	4	オイルシール式	O-ring	FPM rubber	4	Oil seal type
518	オイルシール	FPM	4	メカニカルシール式	Oil seal	FPM rubber	4	Mechanical seal type
520	メカニカルシール	SUS316	4	メカニカルシール式	Mechanical seal	Stainless steel	4	Mechanical seal type
521	シールカバー	SUS304	4	メカニカルシール式	Seal cover	Stainless steel	4	Mechanical seal type
680	ギヤボックス	SS400	1		Gear box	Mild steel	1	
682	ギヤボックス取付板	SS400	1		Gear box plate	Mild steel	1	
683	冷却管	BsTF4	1		Cooler pipe	Copper alloy pipe	1	
684	油受	SS400	1		Oil collector	Mild steel	1	
685	ねじ込みフランジ	SUS304	2		Flange	Stainless steel	2	
686	プラグ	FCMB	3		Plug	Cast iron	3	
702	安全弁カバー	FC200	1		Safety valve cover	Cast iron	1	
704	安全弁	SCS13	1		Safety valve	Cast stainless steel	1	
706	安全弁座	SUS304	1		Safety valve seat	Stainless steel	1	
707	安全弁バネ	SUP6	1		Safety valve spring	Spring steel	1	
712	バネガイド	SS400	1		Spring carrier	Mild steel	1	
713	調整ネジ	SUS304	1		Adjust screw	Stainless steel	1	
714	O-リング	FPM	1		O-ring	FPM rubber	1	
717	安全弁キャップ	FC200	1		Safety valve cap	Cast iron	1	
718	ロックナット	SS400	1		Lock nut	Mild steel	1	
719	弁ガイド	CAC403	1		Valve guide	Bronze casting	1	
901	サイドパッキン	ノンアスシート	2		Side packing	Non asbestos sheet	2	
902	ベアリングホルダパッキン	ノンアスシート	1		Bearing holder packing	Non asbestos sheet	1	
903	ギヤケースパッキン	ノンアスシート	1		Gear case packing	Non asbestos sheet	1	
920	弁カバーパッキン	ノンアスシート	1		Safety V. cover packing	Non asbestos sheet	1	
921	弁キャップパッキン	ノンアスシート	1		Safety V. cap packing	Non asbestos sheet	1	

寸法

Dimension

二軸ねじポンプの吸込口から入った液は二方向に分れ、ケーシングの両側から中央の吐出口へ流れるようにポンプ回転方向に応じたねじ軸を選定しています。

従って右回転用と左回転用のねじ軸は異なりますが、吸込口に対する主軸の位置は自由に選ぶことが出来ますので、対称配置等その都度指示して下さい。

Fittable Screw rotors (shafts) for pump direction are selected so that the liquid taken in from the inlet of the pump is separated into two directions. After going through both sides of the pump casing, it flows to the outlet at the center of the pump casing.

Therefore, screw rotors for clockwise and counterclockwise operation are different, but you can easily choose the position of main rotor (shaft) for suction.

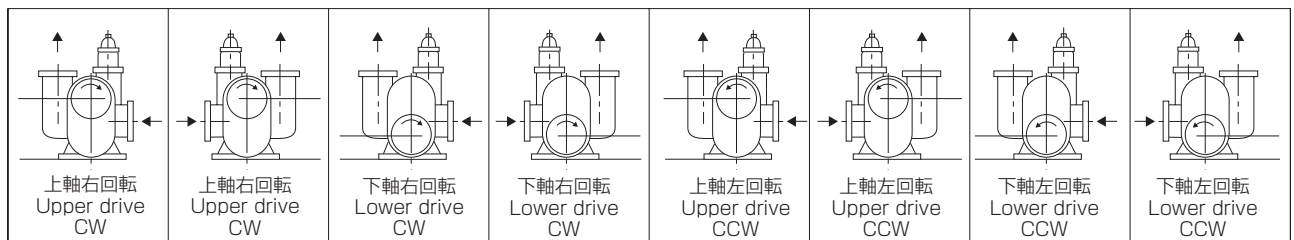
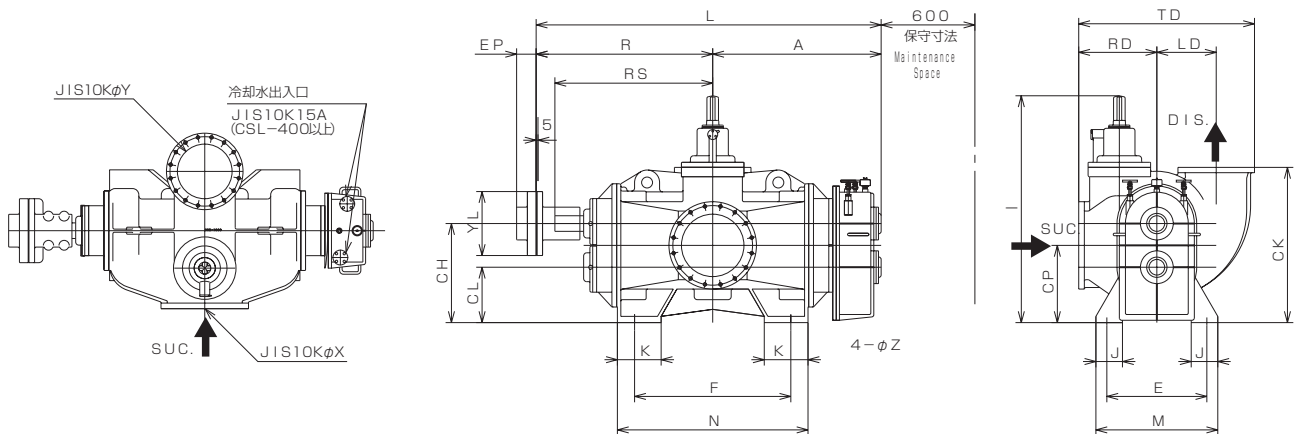

TYPE	BORE		A	R	L	RS	CL	CH	CP	OK	I	G	J	E	M	K	F	N	Z	RD	LD	TD	YL	EP
	X	Y																						
CSL- 50	100	80	490	560	1050	460	170	280	225	450	690	24	95	280	360	120	375	465	24	215	112	420	190	60
CSL- 100	125	100	520	585	1130	490	170	280	225	450	635	24	95	280	360	130	440	530	24	215	120	440	190	60
CSL- 150	150	125	550	630	1205	525	190	322	256	510	715	25	105	320	410	140	440	540	24	240	160	525	240	80
CSL- 200	150	150	590	670	1285	565	200	352	276	550	785	26	125	350	450	170	490	610	24	270	190	600	240	80
CSL- 300	200	200	645	700	1370	590	224	388	306	605	870	28	135	400	500	180	520	650	28	290	220	675	240	80
CSL- 400	250	200	690	745	1470	640	250	438	344	695	985	35	140	450	550	200	580	720	28	310	230	705	260	100
CSL- 500	300	250	800	895	1740	780	280	488	384	770	1080	35	150	500	600	230	740	900	28	360	280	840	330	110
CSL- 750	350	300	935	995	1975	880	300	524	412	825	1230	40	150	600	700	250	880	1070	35	410	300	933	330	110
CSE-1000	400	350	1080	1130	2205	1010	355	635	495	995	1385	40	170	640	780	280	1000	1220	35	500	380	1125	410	125
CSE-1200	400	350	1120	1185	2300	1060	375	687	531	1100	1620	40	200	680	840	300	1020	1250	35	540	400	1185	425	150
CSE-1500	450	400	1215	1265	2475	1130	425	765	595	1190	1710	50	220	740	920	320	1080	1330	35	600	440	1320	520	160

■ 駆動装置

主機・補機・電動機等様々な動力源に対して増減速機駆動、スリッピングクラッチ駆動、インバータ駆動等最適な駆動方法で対応いたします。また、主機・補機の動力を利用して発電機や油圧ポンプを駆動することも可能ですのでお申し付け下さい。

■ Driving gear

We can offer some suitable pump driving method to utilize main engine, aux. engine and electric motor. There are speed-increasing gear driving, reduction gear driving, slipping clutch driving, inverter & motor driving. In addition to, you can drive generator and hydraulic pressure pump by utilizing main engine and aux. engine power.

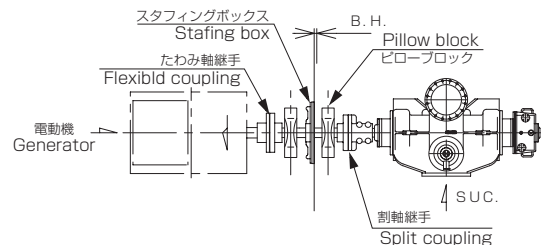
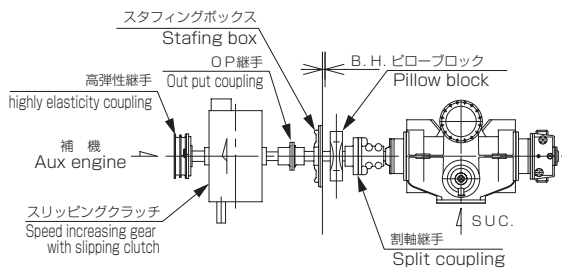
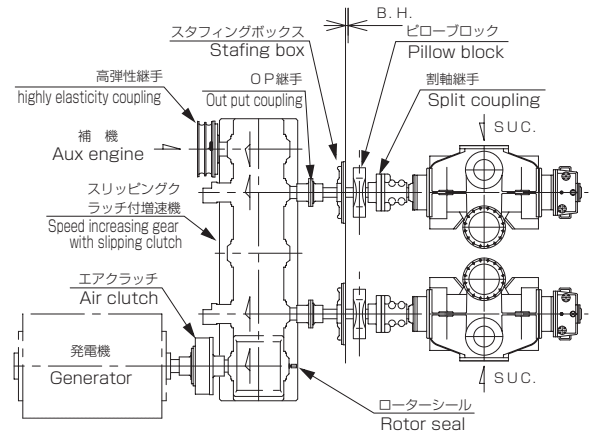
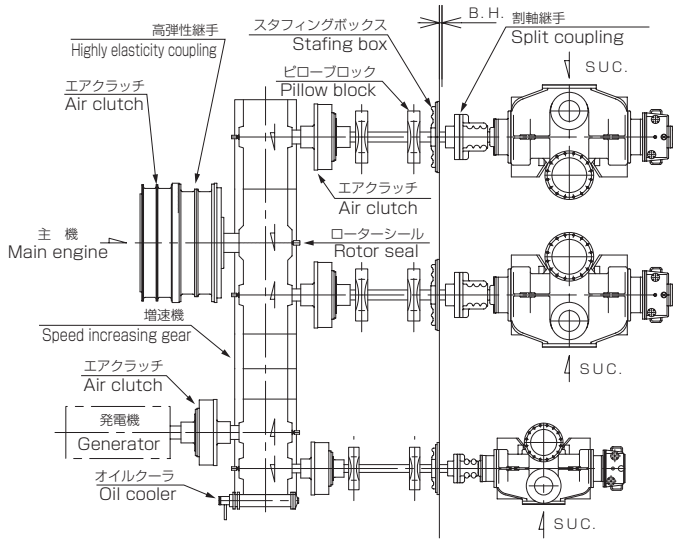

■ スタッフボックス寸法表

■ Staffing Box

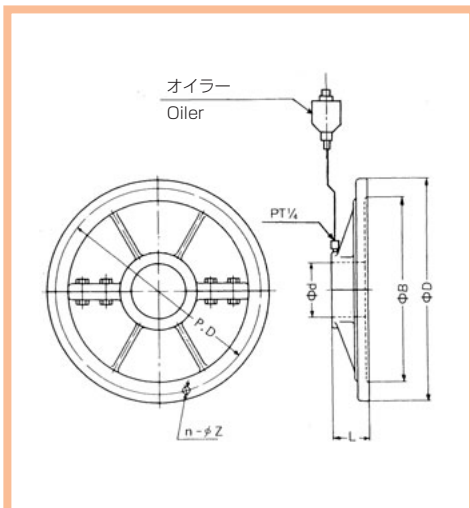

軸径 φd	φD	φB	P.D	L	n	φZ	Oil seal No.	Oiler
45	400	320	360	59	8	14	45 68 12	1/4" × φ75
50							50 72 12	
55							55 78 12	
60							60 82 12	
65							65 90 12	
70							70 92 12	
75							75 100 13	
80	80 105 13							
85	85 110 13							
90	90 115 13							
95	95 120 13							
100	100 125 13							
105	105 135 14							
110	110 145 14							
115	115 145 14							
120	700	600	650	67	16	18	120 155 14	
125							125 155 14	
140							140 170 14	
140							140 170 14	
150	800	700	750	67	18	18	140 170 14	
150							150 180 14	

大晃機械工業株式会社

TAIKO KIKAI INDUSTRIES CO., LTD.

URL <http://www.taiko-kk.com>

- 本 社 ・ 工 場 〒742-1598 山口県熊毛郡田布施町大字下田布施209-1
TEL:(0820)52-3113~4 FAX:(0820)53-1001 E-mail: business@taiko-kk.com
 - 東 京 支 店 〒101-0061 東京都千代田区三崎町3-4-9 水道橋MSビル4階
TEL:(03)3221-8551 FAX:(03)3221-8555 E-mail: tokyo-br@taiko-kk.com
 - 大 阪 支 店 〒541-0048 大阪市中央区瓦町3-4-7 KCビル8階
TEL:(06)6231-6241 FAX:(06)6222-3295 E-mail: osaka-br@taiko-kk.com
- 北京駐在事務所・上海駐在事務所・韓国大晃

- Head Office & Factory 209-1 Shimotabuse, Tabuse-cho, Kumage-gun, Yamaguchi pref. 742-1598 Japan
TEL: 81-820-52-3113~4 FAX: 81-820-53-1001 E-mail: business@taiko-kk.com
 - Tokyo Branch 4th floor, Suidobashi MS Building, 3-4-9 Misaki-cho, Chiyoda-ku, Tokyo 101-0061 Japan
TEL: 81-3-3221-8551 FAX: 81-3-3221-8555 E-mail: tokyo-br@taiko-kk.com
 - Osaka Branch 8th floor, KC Building, 3-4-7 Kawara-machi, Chuo-ku, Osaka 541-0048 Japan
TEL: 81-6-6231-6241 FAX: 81-6-6222-3295 E-mail: osaka-br@taiko-kk.com
- Beijing Office・Shanghai Office・Taiko Korea

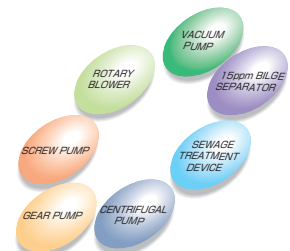

- ISO 9001の認証取得 お問い合わせ先の詳細は別紙【BUSINESS OFFICE NETWORK】をご覧ください。
- ISO 9001 certified For any inquiries, please refer to attached 【BUSINESS OFFICE NETWORK】
- このカタログに記載した製品は性能向上のため予告なしに寸法及び仕様を変更することがあります。
- The sizes and specifications of the products in this catalog are subject to improvement.

2009/09 MUTSUMI