

SIMPLEX-COMPACT

Retractable Fin Stabilizer Type Z

The best of both worlds – stabilization underway and at zero speed

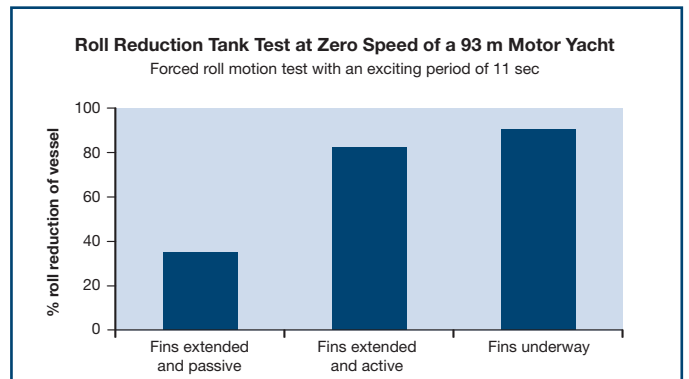
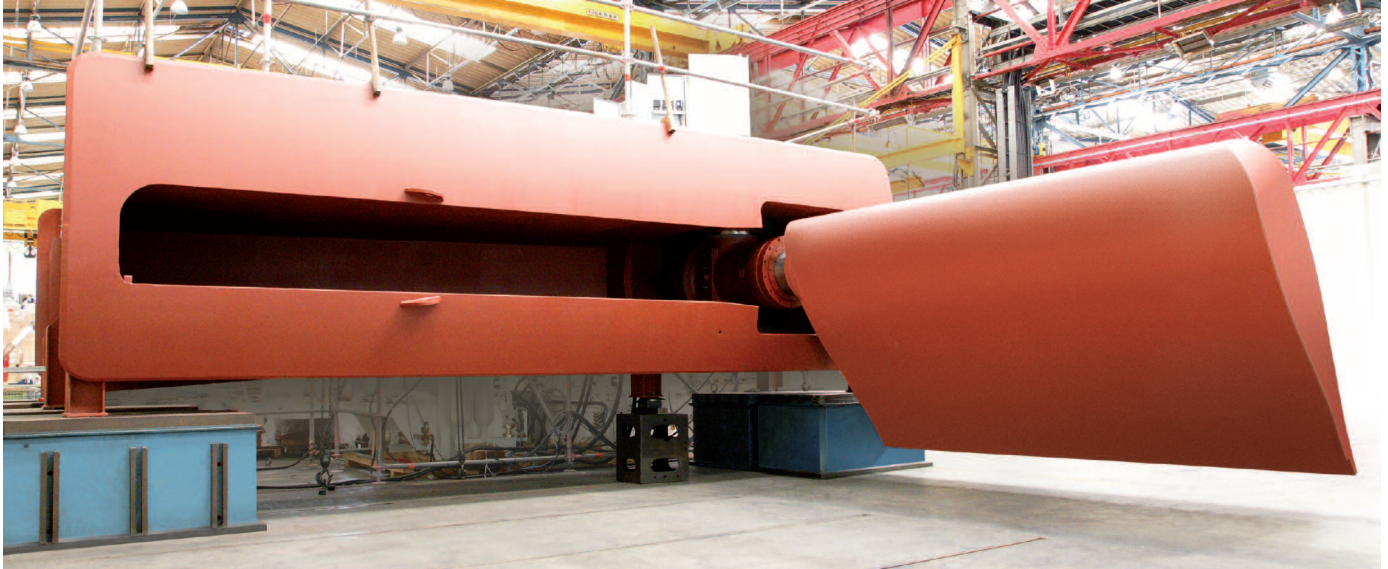

Since the 1960's Blohm + Voss Industries has supplied high-efficiency retractable fin stabilizers to different kinds of vessels worldwide.

The Type Z fin stabilizer has been specially designed and developed for motor yachts and cruise vessels with demanding specifications for stabilization both at zero speed and underway. It utilizes long-time experience and well-proven components from the Type S stabilizer together with a

new fin profile and modified actuator and control system. Numerical analysis and tank tests have been performed to verify the optimal fin shape, working angle and stabilizing performance.

- **New Fin Profile.** One-piece fin specially designed for optimum stabilization.
- **Retractable fins.** Stabilizer fins are stored when not in use.
- **Large fin range available** depending on size and performance requirements of the vessel.
- **Rotary Vane Actuators.** The well proven rotary vane motor has been modified to operate with an angle of $\pm 60^\circ$ to ensure reliable and correct roll reduction at all conditions.
- **Accumulator Supported Hydraulic System** has a very fast response ensuring high stabilizing performance in all conditions.
- The fin stabilizers are operated by **Simplex-Compact Adaptive Control**, which is a highly reliable automatic control system for easy operation and monitoring as well as simple installation.
- **Touch Control Panels** are installed on the bridge and in the ECR to simplify control and supervising of the fin stabilizers.

Blohm + Voss Industries

Blohm+Voss

Stabilization underway and at zero speed

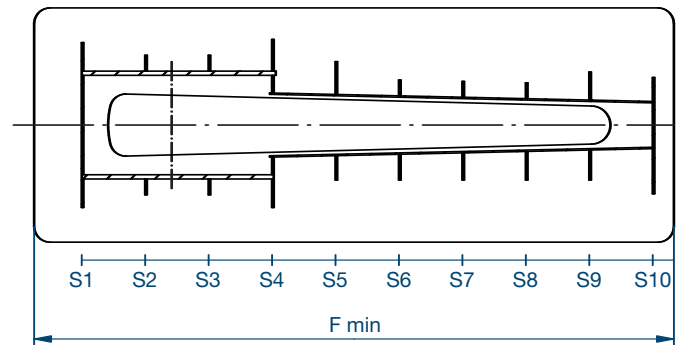
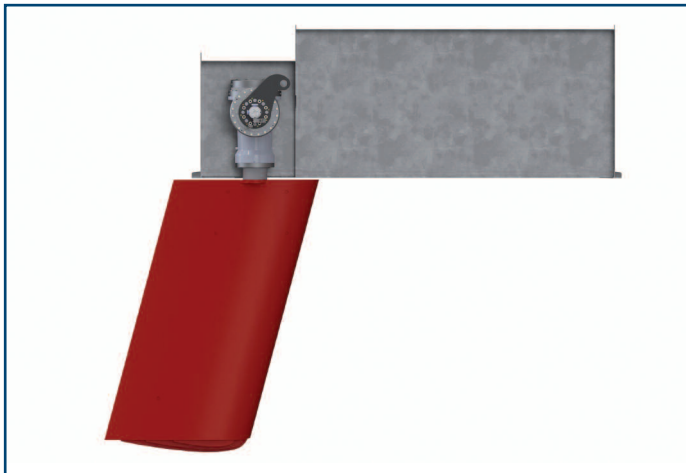
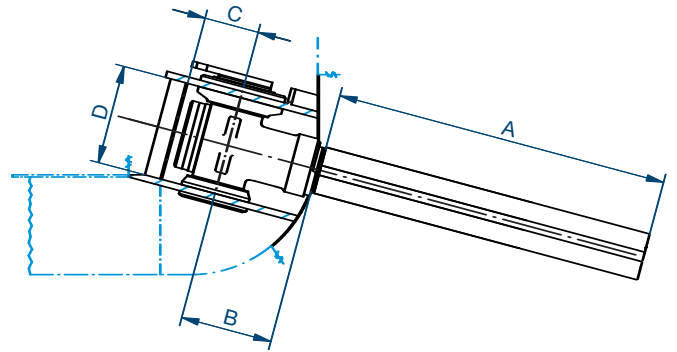
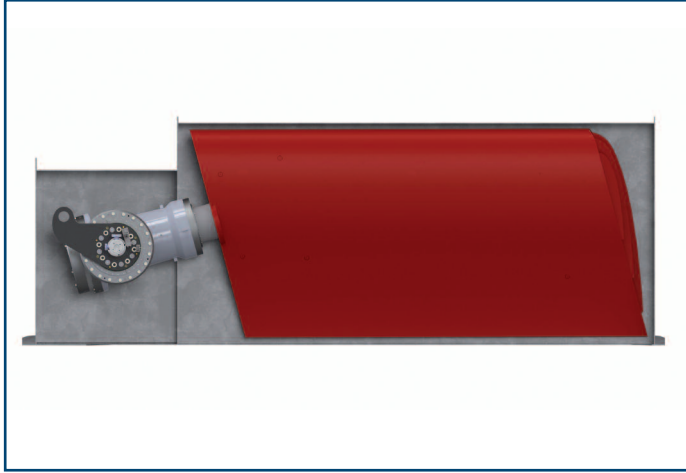

	Z300	Z400	Z500	Z600
Fin area [m ²] up to	9,00	13,00	17,00	21,00
A [m]	4,00	4,80	5,45	6,10
B [m]	0,95	0,99	1,40	1,65
C [m]	0,58	0,69	0,80	1,00
D [m]	0,95	1,22	1,40	1,54
F _{min} [m]	6,20	7,20	8,50	9,60

Blohm + Voss Industries GmbH
P.O. Box 11 22 89
20422 Hamburg, Germany
Phone: + 49 40 30 11 - 26 46
Fax: + 49 40 30 11 - 19 50
E-Mail: sales@bv-industries.com
Internet: www.bv-industries.com