

GRAVINER

Mk6 Oil Mist Detection System



Crankcase explosions due to ignition of oil mist can be disastrous to both vessel and crew, so marine safety equipment on board must be capable of dealing with a possible hazard in seconds. Since the potential hazard was first identified some 50 years ago, the Graviner oil mist detector has been used to monitor oil mist levels on many thousands of merchant ships and has been supplied to almost every ship-owning nation.

Benefits

- Multi-engine capability
- High scan rate – 64 detectors in 1.2 seconds
- Complete flexibility – up to 8 engines on a single system
- Pipe-free installation
- Compact detectors mounted on engine with plug/socket connection
- Control unit located in engine control room or other suitable location, connected to detectors via junction box
- Low initial cost and simple to extend
- Simple cable run between engine and control unit
- 24v DC operation
- No air supply or extractor fans needed
- Event Log

Efficiently lubricated machinery is as critical to the reliability and operating safety of modern diesel engines as it has always been. Rapid advances in lubrication technology and the latest computer aided production techniques have done much in recent years to significantly improve both marine and land-based diesels.

Occasional mechanical failures in the crankcase are inevitable. A minor problem with a bearing shell for example, will cause a 'hotspot' and generate large volumes of oil mist. If not detected quickly, major damage may be caused to the crankshaft and a crankcase explosion may result. Such occurrences may lead to time-charter delay, loss of revenue, salvage claims or even, in extreme cases, serious injuries or fatalities and loss of the vessel.

The sensitivity of early oil mist detectors enabled very advanced warnings to be given of incipient bearing failures. In two-stroke engines, warnings were given up to





5-6 hours before any problems became apparent. As engine design improved, power outputs and bearing loads increased and tolerances to failure rapidly decreased.

To keep pace with these trends, oil mist detector design improved in terms of better sampling and faster response times. The time has now arrived where no further fundamental improvements can be made to existing system concepts, so a radical re-appraisal of Oil Mist Detector operating principles was required. The new Graviner Mk6 OMD is the result.

Approvals

American Bureau of Shipping	(ABS)
Bureau Veritas	(BV)
China Classification Society	(CCS)
China Corporation Register of Shipping	(CCRS)
Det Norske Veritas	(DNV)
Germanischer Lloyd	(GL)
Korean Register of Shipping	(KRS)
Lloyd's Register	(LR)
Nippon Kaiji Kyokai	(NKK)
Polish Register of Shipping	(PRS)
Registro Italiano Navale	(RINA)
Russian Register of Shipping	(RRS)

What causes the problem?

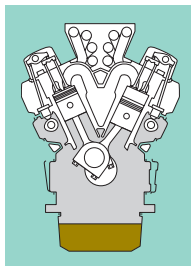

An unprotected engine – no Oil Mist Detector

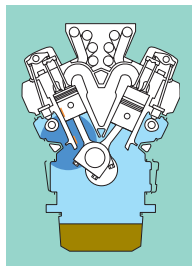

Build-up of oil mist due to 'hotspot' being undetected

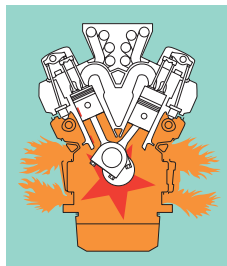

The possible result – ignition of oil mist causing a crankcase explosion

The crankcase of any diesel engine will contain oil mist which is formed by condensation of oil vapour. The generation of oil vapour depends on temperature. Under normal conditions, generation of mist and its re-combination into liquid oil will be in equilibrium and a constant level of oil mist density will be present.

When an incipient mechanical failure generates a 'hotspot', generation of oil mist increases rapidly and far exceeds the re-combination rate. It is this rapid increase in oil mist which must be identified at an early stage, thereby giving warning of the incipient mechanical failure and initiating actions that prevent the oil mist density rising to an explosive level.

Areas of Failure – 2 Stroke Engine

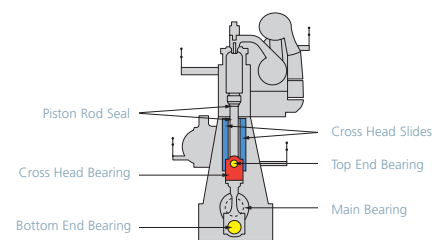

Areas of Failure – 4 Stroke Engine

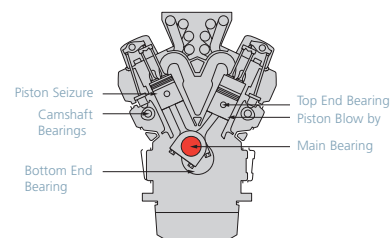



Existing Systems

Oil mist detection requires a means of obtaining mist samples for measurement. This has always been achieved by means of a system of sample pipes fitted to the side of the engine. Later systems with individual detector heads still required some pipework. In addition, internal or external fans or pneumatic air movers were required to obtain the samples for analysis. Engine builders and owners have for some time called for a more flexible approach: A system which is simple to install, with no pipework and with no controls in the engine room. The new Gravier Mk6 Oil Mist Detection System meets these requirements.

System Description

The merging of Gravier and Kidde in 1989 brought together oil mist detection experience and the latest addressable fire alarm technology. This has allowed the Mk6 oil mist detector to be developed as an analogue addressable oil mist detection system, capable of monitoring up to 64 detector heads fitted on up to 8 engines. This is achieved without any sample pipes and with the minimum of cables. Each detector head monitors a single crankspace and is a stand-alone device. When assigned a unique address and supplied with 24V DC it will gather oil mist density data and convert it to a digital signal for transmission via the data cable to the control unit.

The control unit can be configured to monitor from one to eight engines. Detector addresses are identified and associated with the appropriate engine. Deviation levels, average alarm levels and alarm output requirements are all set from the control unit.

The large LCD display will show, on demand, the signal from each detector and indicate the average oil mist level for each engine. In the event of an alarm, the display will immediately show the oil mist signals for the relevant engine. It also enables the individual readings of each detector and the average on an engine to be displayed on demand and automatically under alarm conditions.

In the event of a detector fault, that detector can be isolated without affecting the other detectors on the engine. The system will continue to operate while the faulty detector is replaced.



TYPICAL SYSTEM CONFIGURATION

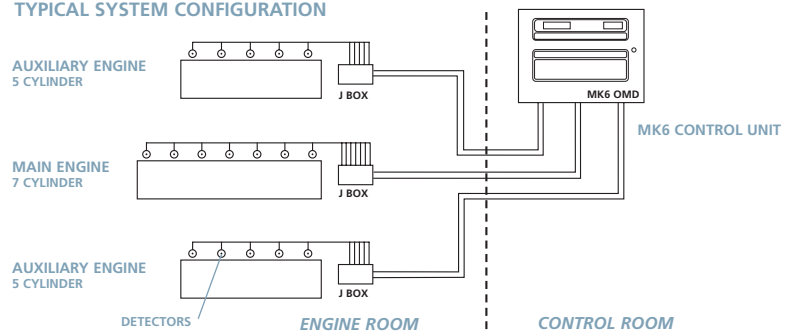

4 GRAVINER

Technical Data

Oil mist detection using well proven sampling method. System is selectable to scan between 1 and 64 detectors. Microprocessor electronics ensures very high degree of active fault indication. Each detector can be individually measured to enable condition monitoring of each crankspace.

Construction	Detector: Black Zytel 70G30 Nylon 66 Junction Box: Cast Aluminium Control Unit: Painted mild steel enclosure
Response time	Less than 1.2 seconds for a 64 detector system.
Sensitivity	Detects average crankspace oil mist densities between 0.3mg/l and 1.3mg/l. Easily adjustable by customer to suit individual engine (lower explosion limit 30 - 50mg/l depending upon oil type). Detects variation of individual crankspace densities from the average of between 0.05mg/l and 0.5mg/l (simple adjustment by customer).
Operating Temperature	Detector and Junction Box: 0 - 70°C (ambient and sample temperature) Control Unit: 0 - 55°C ambient.
Storage temperature	-20°C to +60°C
System Protection	Detector and Junction Box: Designed to meet IP65. Salt fog immune. Control Unit: Designed to meet IP32.
Operating Voltage	24V DC (+30% -25%)
Power Consumption	Detector: 116mA Control Unit: 215mA
Protection	By self re-settable fuse inside Control Unit, junction box 4.5 amp fuse
Insulation	Flash tested to 2000V for 1 minute
Immunity to noise	System tested to requirements of classification societies including: - Radiated susceptibility to radiated noise - Conducted susceptibility to electrical noise - Short duration supply interruption - 1kV high frequency transient voltages.
System Outputs	Fault alarm: 1 set volt-free change-over relay contacts. Relay normally energised when system is powered. De-energises for fault or test condition. Main alarm: 1 set volt-free change-over relay contacts. Relay normally energised when system is powered. De-energises for alarm or test condition. Engine slow down: 8 sets of volt-free change-over relay contacts. Relays normally de-energised when system is powered. Energises for alarm or test condition.
Output relay contacts	30V 1Amp DC
System dimensions (L x W x H) (mm)	Detector: 95 x 90 x 175 Junction Box: 260 x 160 x 90 Control Unit: 500 x 290 x 121
System weights (kg)	Detector: 0.6 Junction Box: 2.3 Control Unit: 6.6



FujiMetallock
Brasil

**Equipamentos e peças para indústria
NAVAL e OFFSHORE & serviços pós-venda.**

Rua da Gamboa, 281. Santo Cristo
Rio de Janeiro - RJ. BRASIL
CEP: 20220-324 - FONE: (21) 2516-5561
vendas@fujimetallock.com.br
www.fujimetallock.com.br

Kidde Fire Protection operates a continuous programme of product development. The right is therefore reserved to modify any specification without prior notice and Kidde Fire Protection should be contacted to ensure that the current issues of all technical data sheets are used.

Kidde Fire Protection

Thame Park Road, Thame, Oxfordshire OX9 3RT

Tel: +44 (0)1844 265003. Fax: +44 (0)1844 265156. E-mail: info@kfp.co.uk Web: www.kfp.co.uk